

CATERPILLAR BOWL 1290375 NEW

Product Images

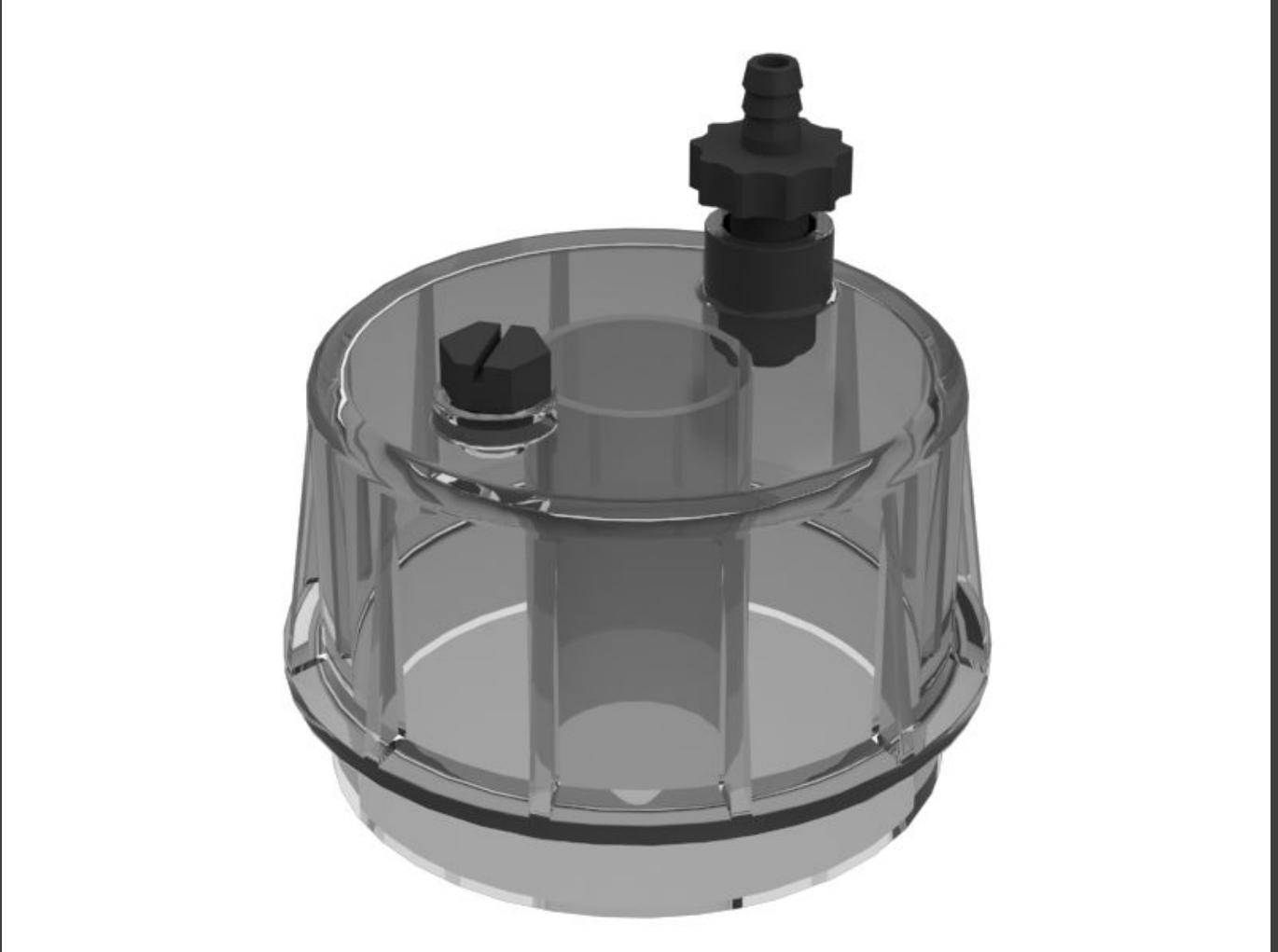

Description

Fuel/water separator bowls catch the fuel contaminants that are removed during the filtration process while also keeping the filter enclosed from the environment.

Attributes:

- Transparent plastic bowl assembly with drain plug
- Spin-on assembly
- Thread size: 3-3/4-10 UNS-2A

Application:

Consult your owner's manual or contact your local Cat Dealer for more information.

Additional Information

Brand	CATERPILLAR	
Condition	ORIGINAL	
Applications suitable (detailed)	Name	Models
	EARTHMOVING COMPACTOR	836 836G
	WHEEL-TYPE LOADER	988F 988F II 988G 990 990 II
	CHALLENGER	65E 75D 75E 85D 85E 95E
	GENERATOR	SR4 SR4B SR5
	ENGINE - GENERATOR SET	3406C 3412C 3412 3456 C18 C27 C32 PM3456
	ENGINE - TRUCK	3126E C-10 C-12 C11
	OFF-HIGHWAY TRUCK	769D 771D 772B 773B 773D 773E 775B 775D 775E
	ENGINE - INDUSTRIAL	3126B 3176B 3176C 3196 3304B 3306 3306B 3406B 3406C 3406E 3408E 3412 3412C 3412E 3456 C-10 C-12 C-15 C-16 C-9 C13 C15 C18 C27 C32 C9 SBF214 SUF557
	ARTICULATED DUMP TRUCK	725 730 735 740 D350E II D400E II
	COLD PLANER	PM-565 PM-565B
	MOTOR GRADER	163H 140H 143H 14H 160H 16H 24H
	WHEELED EXCAVATOR	W345B II
	WHEEL DOZER	834B 834G 844
	EXCAVATOR	345B 345B II 345B II MH 345B L 365B 365B II 365B L 385B 5090B 5110B
	WHEEL TRACTOR-SCRAPER	621G 623G 627G 631D 631E 631G 633D 633E II 637D 637E 637G 639D 651E 657B 657 657E
	TRACK-TYPE TRACTOR	D10N D10R D6G D6G2 LGP D6G2 XL D7G D8R D7G2 D9L D9N D9R

Name

Models

LOAD, HAUL, DUMP

R1600 R1700G R2900