

CATERPILLAR VALVE GP 1291101 NEW

Product Images

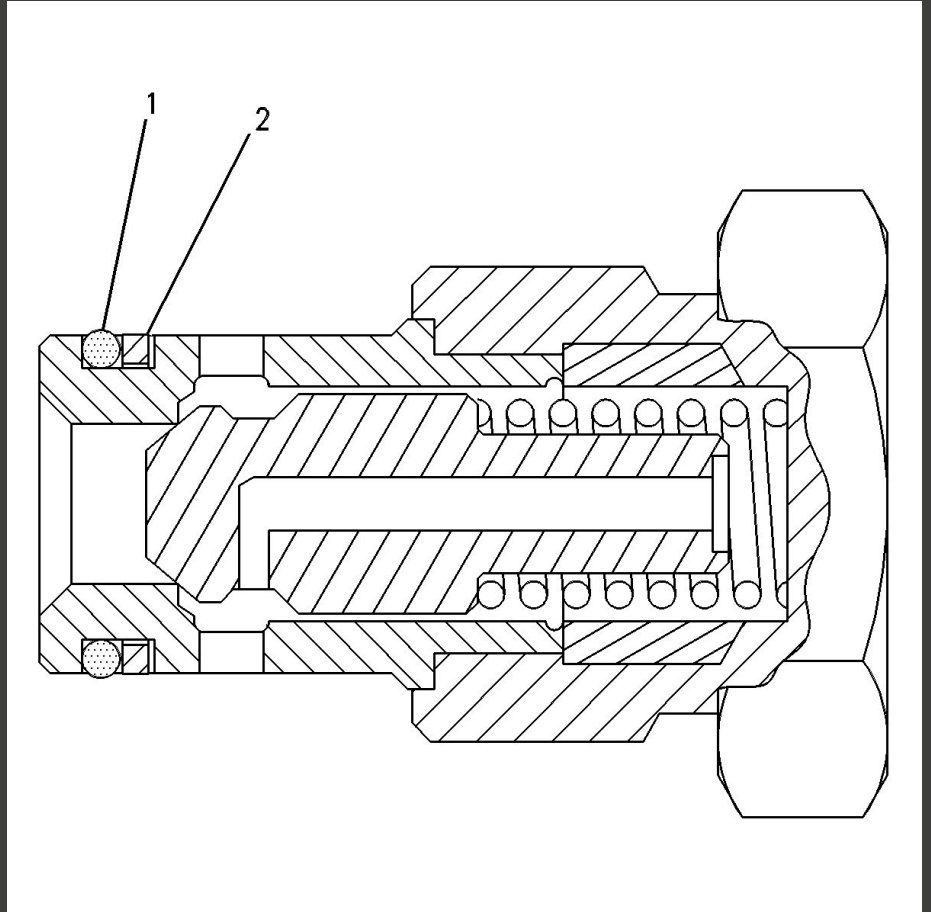

Description

Description: Cat check valve assemblies are a two-way valve that allow free flow in one direction and reverse flow when an external signal is applied. Attributes: Includes 2 service repair parts Application: Cat check valve assembly is used in fuel filter systems. Consult your owner's manual or contact your local Cat dealer for more information.

Additional Information

Brand	CATERPILLAR	
Condition	ORIGINAL	
Applications suitable (detailed)	Name	Models
	WHEEL-TYPE LOADER	938F 938G 950G 960F 962G
	CHALLENGER	35 45 55
	WHEEL-TYPE SKIDDER	525B 535B
	TRACK-TYPE LOADER	953C 963C
	ENGINE - INDUSTRIAL	3116
	FOREST PRODUCTS	533 539 543 570 550 574 580 TK370 TK371 TK380 TK381
	MOTOR GRADER	120H NA 120H 120H ES 135H 135H NA
	WHEELED EXCAVATOR	M320 M325B
	PAVING COMPACTOR	CB-634C CB-634D CP-533C CP-533D CP-563 CP-563C CP-563D CS-531C CS-531D CS-533C CS-533D CS-563 CS-563C CS-563D CS-573D CS-573C CS-583 CS-583C CS-583D
	ASPHALT PAVER	AP-1000B AP-1050B AP-1055B AP-900B BG-240C BG-2455C BG-245C BG-260C
	PIPELAYER	561M
	EXCAVATOR	320B 320B L 320B N 320B S 322B 322B L 322B LN 322C 322C FM 325B 325B L 325B LN M318
	INTEGRATED TOOLCARRIER	IT38F IT38G IT62G
	WHEEL TRACTOR-SCRAPER	613C 613C II
	TRACK-TYPE TRACTOR	D5M D6M